

 **PIBIVIESSE**

General Catalogue

Rotary Control Valves
Rotary On-Off Valves

Contents

Rotary ON-OFF and Control Valves

Applicable Standards

| | |
|------------------------------|---|
| List of applicable standards | 5 |
|------------------------------|---|

General Information

| | |
|------------------------------|---|
| Product range | 6 |
| ON-OFF valves | 6 |
| CAGEBALL control ball valves | 6 |
| Sizes | 6 |
| Pressure ratings | 6 |
| Temperature range | 6 |
| Materials | 6 |
| Actuation | 7 |
| Quality assurance system | 7 |
| CE marking | 7 |
| API registrations | 7 |
| Fire safe certifications | 7 |
| Applications | 7 |

Technical features

| | |
|------------------------|----|
| Design | 8 |
| Trunnion mounted balls | 8 |
| Body joints | 8 |
| Port sizes | 8 |
| Stem features | 8 |
| Seat features | 9 |
| Emergency seat seal | 9 |
| Antistatic | 9 |
| Extended stem | 10 |
| Extended bonnet | 10 |
| Pups | 10 |

Testing

| | |
|---------------------------------|----|
| Available Non Destructive Tests | 11 |
| Special tests | 12 |
| Bending tests | 12 |

Rotary Control Valves

CAGEBALL™ Concept

| | |
|------------------------|----|
| Operational properties | 13 |
| Self cleaning | 13 |
| Applications | 14 |
| Benefits | 14 |
| Options | 14 |
| Technical properties | 15 |

HYPER CAGEBALL™ Concept

| | |
|------------------------|----|
| Operational properties | 16 |
|------------------------|----|

HYPER CAGEBALL™ Multistage Concept

| | |
|------------------------|----|
| Operational properties | 17 |
|------------------------|----|

Guidelines

| | |
|----------------|-------|
| General | 18 |
| Nomenclature | 18 |
| Valve noise | 19 |
| Velocity | 19 |
| Pressure drop | 19 |
| Dynamic torque | 19 |
| Turndown | 19 |
| Applications | 20-21 |

CAGEBALL™ Cv Table

| | |
|-----------------------|----|
| Sizing coefficient Cv | 22 |
|-----------------------|----|

PRODUCT OVERVIEW

On-Off

CageBall

HyperCage

*HyperCage
Multistage*

*Side
entry*

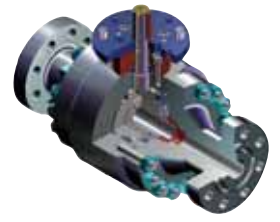
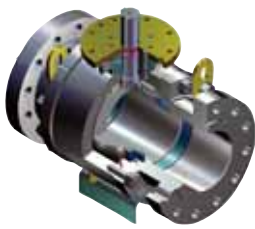

*Top
entry*

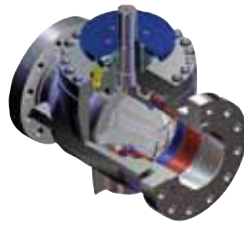

*Fully
welded*

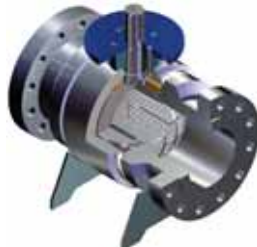
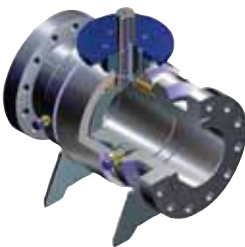

Rotary ON-OFF and Control Valves

Applicable Standards

PIBIVIESSE ball valves are in accordance with API, ASME and B.S. requirements.

The following list contains the most important applicable standards for ball valves.

PIBIVIESSE valves may be designed, manufactured and tested in accordance with other international standard on request.

API - American Petroleum Institute

| | |
|-----------|--|
| Spec. 6A | Specification for wellhead and christmas tree equipment |
| Spec. 6D | Specification for pipeline valves |
| Spec. 17D | Specification for subsea wellhead and christmas tree equipment |
| Spec.RP6F | Recommended practice for fire testing of valves |
| Spec. 6FA | Specification for fire testing of valves |
| Std. 598 | Valve inspection and test |
| Std. 605 | Large diameter carbon steel flanges |
| Std. 607 | Fire test for soft seated quarter -turn valves |

ASME - American Society of Mechanical Engineers

| | |
|--------------|--|
| ASME-B 16.5 | Steel pipe flanges and flanged fittings |
| ASME-B 16.10 | Face-to-face and end-to-end dimensions of ferrous valves |
| ASME-B 16.25 | Butt welding ends |
| ASME-B 16.34 | Steel valves - Flanged and butt welding ends |
| ASME-B 31.3 | Chemical plant and petroleum refinery piping |
| ASME-B 31.4 | Liquid petroleum transportation piping systems |
| ASME-B 31.8 | Gas transmission and distribution piping systems |
| ASME-B 46.1 | Surface texture |

ISO - International Organization for Standardisation

| | |
|-----------------|--|
| UNI EN ISO 9001 | Quality management systems - Requirements |
| ISO 9004 | Quality management systems elements - Guideline for performance improvements |

BSI - British Standards Institute

| | |
|--------------|---|
| BS-EN 102222 | Specification for steel forgings for pressure purposes |
| BS-EN 10213 | Specification for steel castings for pressure purposes |
| BS 1560 | Steel pipe flanges and flanged fittings |
| BS 2080 | Face-to-face, centre-to-face, end-to-end and centre-to-end dimensions of flanged and butt welding end steel valves for the petroleum, petrochemical and allied industries |
| BS-EN 1092 | Flanges and their Joints- Circular flanges for pipes, valves, fittings and accessories, PN designated |
| BS-EN 1515-1 | Flanges and their Joints |
| BS 5146 | Inspection and test of steel valves for the petroleum, petrochemical and allied industries |
| BS 5351 | Steel ball valves for the petroleum, petrochemical and allied industries |
| BS 6755 | Testing of valves |

MSS – Manufacturers Standardization Society

| | |
|-------|---|
| SP 6 | Standard finishes for contact faces of pipe flanges and connecting - end flanges of valves and fittings |
| SP 25 | Standard marking system for valves, fittings, flanges and unions |
| SP 44 | Steel pipeline flanges |
| SP 45 | By-pass and drain connection standard |
| SP 55 | Quality standard for steel castings-visual method |
| SP 61 | Hydrostatic testing of steel valves |
| SP 72 | Ball valves with flanged or butt welding ends for general service |

NACE - National Association of Corrosion Engineers

| | |
|----------|--|
| MR-01-75 | Sulfide stress cracking resistant metallic materials for oil field equipment |
|----------|--|

CEI/IEC

| | |
|-----------------|---|
| IEC 60534 | Industrial process control valves |
| IEC 60529 | Degree S or R protection provided by enclosures (IP CODE) |
| IEC 61508/61511 | SIL/PFD definition & evaluation |

Rotary ON-OFF and Control Valves

General Information

Product range

PIBIVIESSE designs and manufactures a wide range of high performance manually operated or automated, ON-OFF and CONTROL Ball Valves for any kind of fluid handled in the oil, gas, water, steam and power generating industry.

The basic ball valve design is a bolted construction which simplifies field service and maintenance. Our product line is then completed with our top entry ball valves that can be easily serviced without removing the valve from the line and with our fully welded line that is typically used for pipeline/buried application or for sub-sea lines.



Trunnion Mounted ON-OFF ball valves

Side entry-bolted body, top entry and fully welded are available with Metal or Soft seats. Specific designs have been developed for HIPPS to SIL3, Sub-sea, Cryogenic, High Temperature, Slurry / Erosive applications in addition to Three way ball valves and Custom made ball valves.



Trunnion Mounted CONTROL ball valves

Specifically designed to handle very high flow rates or very high differential pressures our exclusive and patented CAGEBALL™, HYPER CAGEBALL™ and HYPER SILENT™ concepts have been integrated with the basic features of our trunnion mounted On-Off ball valves.



Sizes

On-off valves: from 1/2" to 60"

Control valves: from 1" to 60"

Pressure ratings

From ANSI 150 to ANSI 2500-4500;
from API 2000 to API 15000

Temperature range

From -196°C (-320°F)
to +800°C (+1472°F)

Materials

All our products are available in a wide selection of materials ranging from Low Temperature Carbon Steel up to Inconel 625, Incoloy 825 and more.



Rotary ON-OFF and Control Valves

General Information

Actuation

Pibiviesse valves can be supplied with all types of actuators, i.e. pneumatic, hydraulic, Gas Over Oil, electric, etc.

They are tested as a control unit package prior to delivery.



Quality assurance system

All our manufacturing operations are covered by a quality assurance program, which has been audited and qualified in accordance with:

ISO 9001 – 2000 & API Q1

API 6D – ISO 14313

API 6A - ISO 10423

API 17D

ASME sect III

IEC 61508 SIL 3

PED 97/23/EC

ATEX 94/9/EC



CE Marking

Pibiviesse has been authorised to manufacture its products with CE logo in accordance with Pressure Equipment Directive 97/23/EC since June 2001.

API registrations

Pibiviesse has been granted from the American Petroleum Institute the autorisation to use the API 6A and the API 6D monograms. The API 6A includes the product specification level 4, which is the highest quality level specified. Licence numbers are:

API 6A nr 0370

API 6D nr 0215



Fire safe certifications

B.S.5146 – B.S.6755

API 6FA – API 607 – API RP6F

Applications

Oil & Gas industry

LNG & GTL

Gas transmission and distribution

Power industry and steam generation

Petrochemical industry

Water transmission & desalination plants



Rotary ON-OFF and Control Valves

Technical features

Design

All Pibiviesse ball valves are a bolted construction which simplifies field service and maintenance. Top entry valves can be easily serviced without removing the valve from the line. All the components of the side entry ball valves and all the internals of the top entry ball valves are made of forgings. Only the body of the top entry ball valves is in the cast form. Fully welded ball valves are identical from internals design and materials selection to side entry valves. All body joints and alternatively also the bonnet joints are welded to offer 100% leak-free joints.



Trunnion mounted balls

Trunnion mounted balls permit ease of operation, minimizing the operating torque and reducing seat seal wear.

Body joints

Double o-rings, or the combination of o-rings and gaskets, grant a perfect and safe sealing of body and trunnion. Thus making the PIBIVIESSE ball valves suitable for both above ground and buried installation.

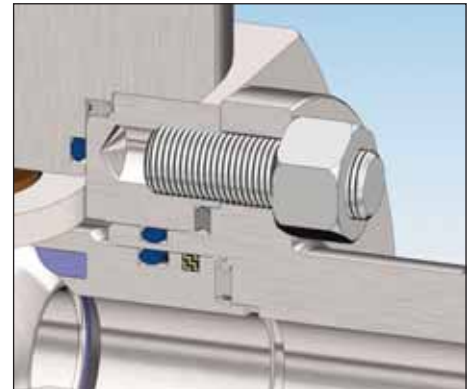

Port sizes

Expansion outlet or conical trim are also available to keep the unexpected dangerous limit. (Avoiding high frequency vibration).

Stem features

Antiblowout stem permits the replacement of the stem seals with the valve in the fully closed position. The stem seal integrity is achieved by the use of three o-rings (or two o-rings and a graphite gasket). The upper o-ring (or the graphite gasket) can be replaced with the valve in line and under pressure. The ball and stem are separate components which lessens torque. Stem and trunnion are supported by P.T.F.E. impregnated steel bearing sleeves. Provision for the injection of emergency sealant is available on request.

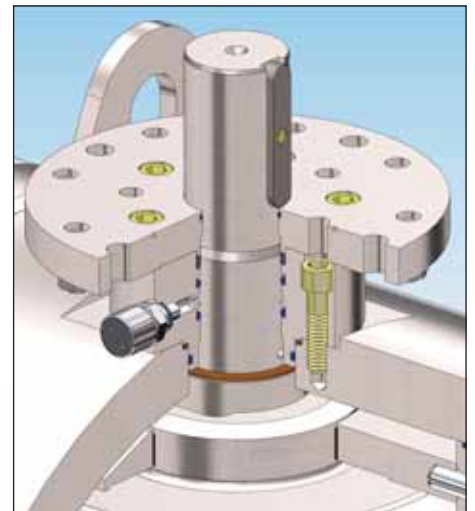

Rotary ON-OFF and Control Valves

Technical features

Seats features

Independent floating spring loaded seats are always in contact with the ball to provide an effective tight seal even at low differential pressures.

Independent upstream and downstream seats permit draining of fluid from the body cavity, allowing double block and bleed operation.

With the single sealing feature, there is an automatic body cavity release of over pressure to the line through the down stream seat.

Double sealing feature (available on request), maintains the sealing capacity of the valve even in the case of failure of the up stream seats. Body cavity over pressure in this case can be released through a relief valve to atmosphere.

A combination of double sealing features on the downstream side and single sealing on the upstream seat is available on request.

This configuration maintains the sealing capacity of the valve in case of failure of the upstream seat and release of the body cavity over pressure through the upstream seat.

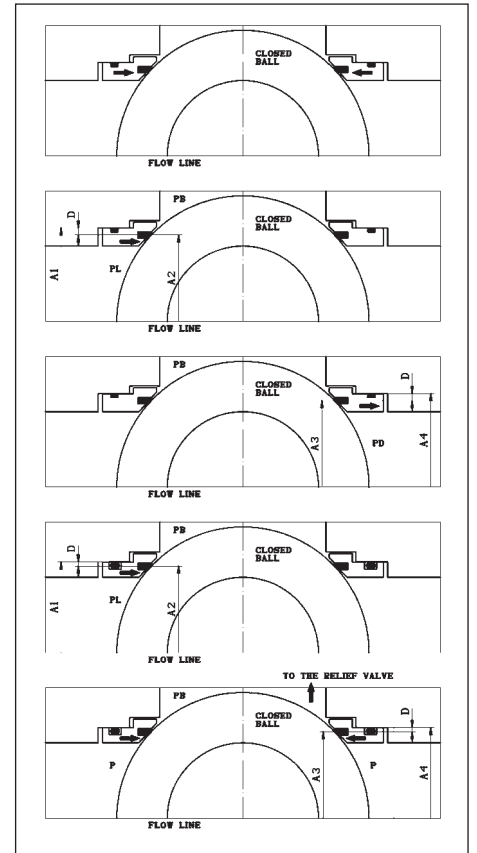

Emergency seat seal

An emergency sealant injection system is available on request which can restore the sealing integrity if damage is caused to the sealing surfaces.

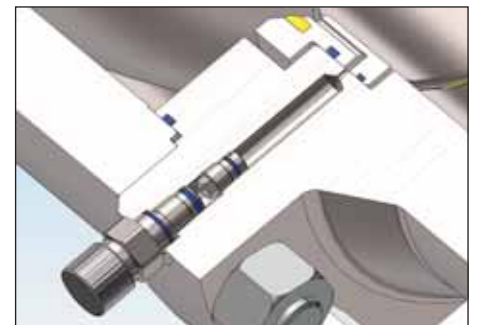

Antistatic

A stainless steel or Inconel spring between the stem and the ball or between the stem and the gland plate permits electrical continuity between all valve components.

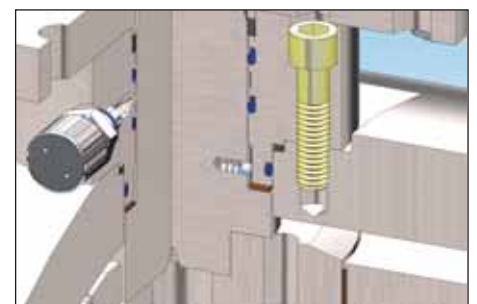

Rotary ON-OFF and Control Valves

Technical features

Extended stem

When ball valves are to be installed below ground on buried pipelines or where not easily accessible, operators can be remote mounted by means of suitable stem extension. Drain lines and grease injectors (if required) will be piped up to the top of the extension for an easier access.

The distance between valve centreline and operator handwheel must be specified.

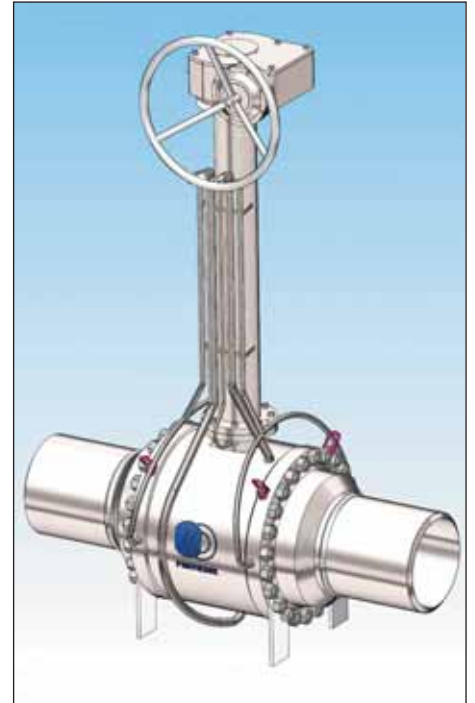

Extended bonnet

Ball valves to be used in low temperature/cryogenic service are equipped with extended bonnet to allow vapour space between body cavity and gland seals. This feature preserves stem seals from damages that may occur during operation at cryogenic temperatures, and allows stem seal servicing even on valves installed on insulated lines. Vapour space length or insulating thickness shall be specified.

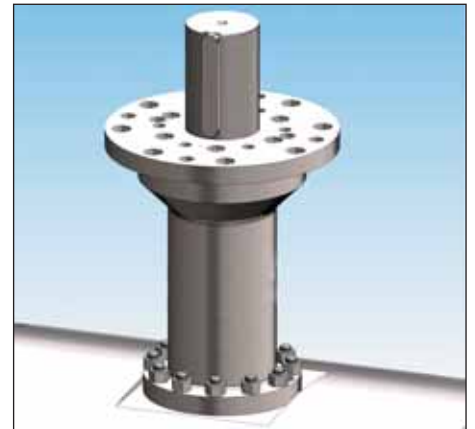

Pups

Butt welding ends valves may be supplied with transition pieces (PUPS) to avoid any risk of seat and seal damage during welding and post weld heat treatment operations. Length of pups and matching pipe details must be specified.



Rotary ON-OFF and Control Valves

Testing

Available Non Destructive Tests

| DESCRIPTION OF TEST | APPLICABLE STANDARDS | EXTENT OF TEST |
|----------------------------------|---|--|
| Dye Penetrant | ASME V – Art. 6 and 24 ASTM E165 ASME B16.34 – Appendix III | 10% on pressure containing parts For non magnetic materials (100% upon customer request) |
| Magnetic particles (dry and wet) | ASME V – Art. 7 and 25 ASTM E709 ASME B16.34 – Appendix II | 10% on pressure containing parts For non magnetic materials (100% upon customer request) |
| X and Gamma ray | ASME V – Art. 2 and 22 ASME VIII – Div.1 ASME B16.34 – Appendix I ASTM E142 - E94 - E446 - E186 - E280 | Upon customer request |
| Ultrasonic | ASME V – Art. 4 and 23 ASME VIII – Div.1 ASTM A388 | Upon customer request |
| Hydrostatic and pneumatic | API 6D and API 6A BS 5146 and BS 6755 MSS-SP61 and customer specs | 100% of all valves |
| Stem torque | API 6D and customer requirements | 100% of actuated valves 10% of manual valves |
| Visual and dimensional | Applicable ASTM Stds MSS-SP44 and SP55 ASME B16.34, B16.5, B16.10 API 6D and 6A, BS 2080 | 100% of rough and finished machined components and assembled parts |
| Alloy verification | PIBIVIESSE procedures for Thermo Scientific Niton XLT 898 Spectro-Ametek SPECTROTEST CCD | Upon customer request |
| Hardness | NACE MR01-75 | 100% of wetted components |
| High pressure gas test | PIBIVIESSE procedures and customer specifications | Upon customer request |

Other additional non destructive or destructive examinations may be performed to customer requirements or specifications. Please contact our Q.A. or Q.C. departments for additional information and clarification.

Rotary ON-OFF and Control Valves

Testing

Special tests

PIBIVIESSE ball valves are subjected to extremely severe special tests, far in excess of the requirements of the API and ANSI Standards. A large number of valves have been subjected to enhanced tests.

Special Tests such as high pressure N₂/He shell and seats tests, low temperature (cryogenic) shell and seat test, high temperature (up to 120°C) leak and operational tests have been performed on customer request by independent laboratories in Italy, U.K. and Holland.

Some high pressure ball valves, of standard trim and design up to 20"-1500 lbs. size, have been subjected to an extremely severe test program by Soba-Qualitest - TUV in Holland.

As part of the approval procedure for one of the largest oil companies, these tests included:

- Cycling opening-closing tests at 1.1 max rated pressure;
- Body and seat leak tests at 1.5 and 1.1 max rated pressure;
- Delayed torque tests;
- Body cavity overpressure relief tests
- Double block and bleed tests.

All the tests were performed at ambient temperature, high temperature (120°C) and again at ambient temperature.

Test reports are available on request.

Bending tests

Bending tests to verify the performance of the valves, when subject to the bending loads transmitted by piping, have been performed both on side entry and top entry ball valves. Tests included checks of possible body distortion, torque and leakage rates.

The bending tests have been performed with in-thermal pressure exceeding the maximum rated pressure on top entry ball valves.

Certificates are available.

Bending tests have been performed in both operational and maintenance modes.



Rotary Control Valves

CAGEBALL™ Concept

Operational properties

Pibiviesse Cage-Ball control valves are enhanced second generation of control ball valve design. It is based on changeable internal cage which divides the pressure drop in stages.

The attenuating plates, mounted into a replaceable cartridge, are offset by an optimally designed angle to obtain a number of significant control advantages. The noise, cavitation and high frequency vibration are almost eliminated.

The turndown is increased to 250.

The new balancing tails significantly reduce the dynamic forces generated by the attenuating plates.

This balanced trim offers the following advantages: lower torques, increased accuracy, ease of operation and reduced load on the stem module.

Extra large bearings can handle pressure and dynamic loads and vibrations do not affect Cage-Ball valves performance. This guarantees stability during throttling operation.

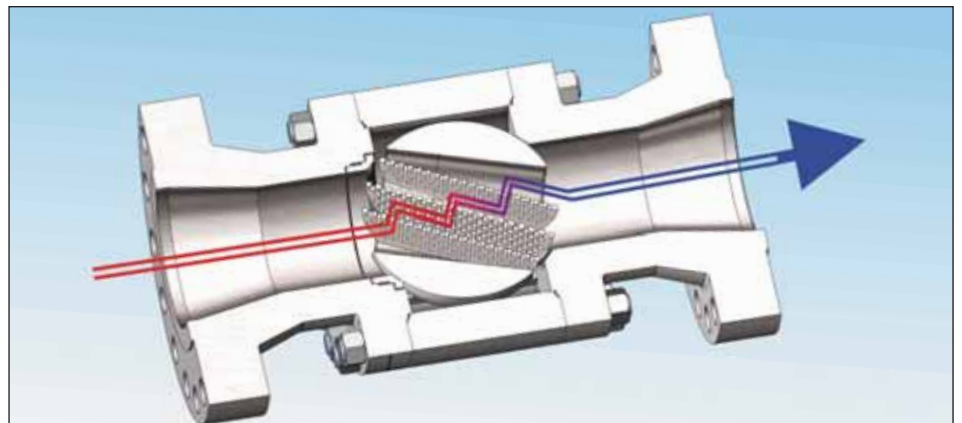
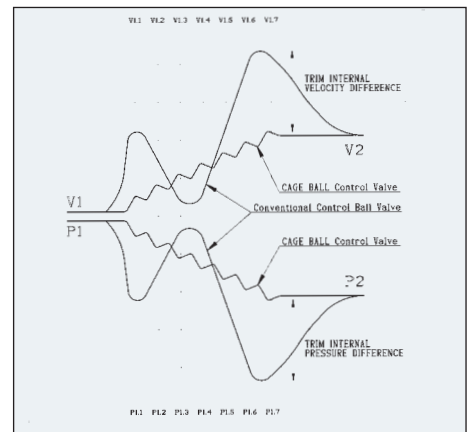
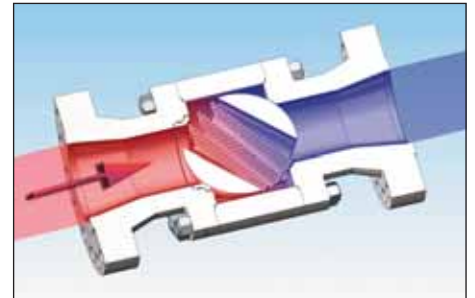

Self cleaning

A new feature is the self-cleaning effect built in the trim design. When the valve is in large openings (this happens if the attenuating plates are plugged by dirt or solid that might be in the flowing medium) the angle between the flow axis and the plates is optimal to generate a depressurization behind the plates. This cleans the plugged holes and significant savings on the maintenance can be achieved.

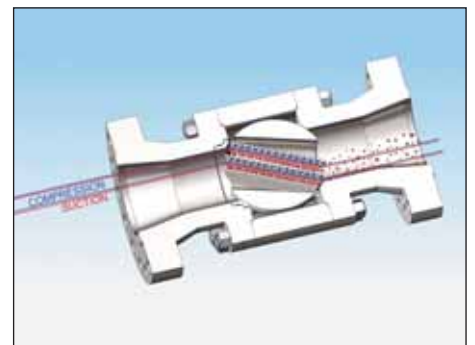

Rotary Control Valves

CAGEBALL™ Concept

Applications

Due to high flow factors as FL, Xt and Z along with exceptional flow capacity, Cage-Ball valves give optimal solutions in various severe control applications like:

Flow control on loading arms (including top-ups) – Pumps and system start-ups – Partial throttling – Compressor control.

By-pass on transmission lines – Surge relief – Smooth depressurizations – Equalization/balancing and venting.

Blow-down (with reduced Hydrate formation) – Switching (where smooth transitions are required).

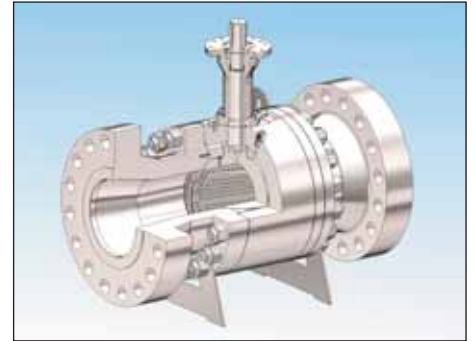

Benefits

Benefits include economy in large mass flow-rates, low noise and/or non-cavitating fluid handling, axial flow in large flow-rates also means lower turbulence, vibrations and balanced constant torque development. Extra safety factors can be smaller in sizing actuators, meaning savings in actuator size, control accessories and air consumption.

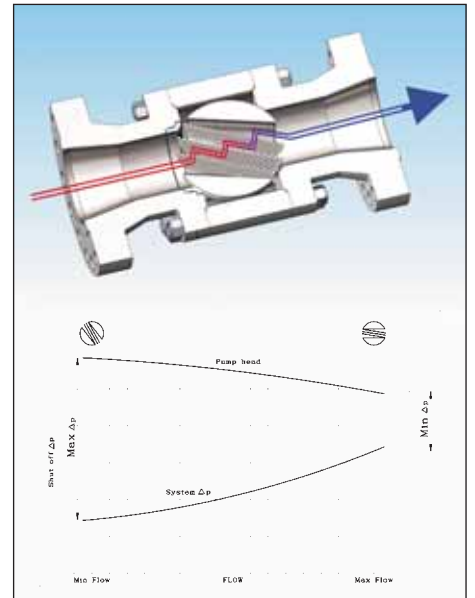

Options

These control valves can have reduced trim or expanded outlet equipped with integrated flow restrictor resulting in linear flow characterization or constant Dp over the valve. In addition with a large choice of materials and seating arrangements, combined with full or reduced bore configurations the Cage-Ball control valves can be tailored to suit actual service conditions.

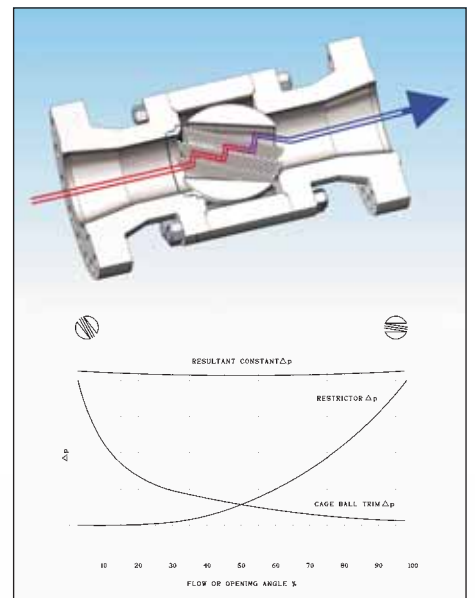

Rotary Control Valves

CAGEBALL™ Concept

Technical properties

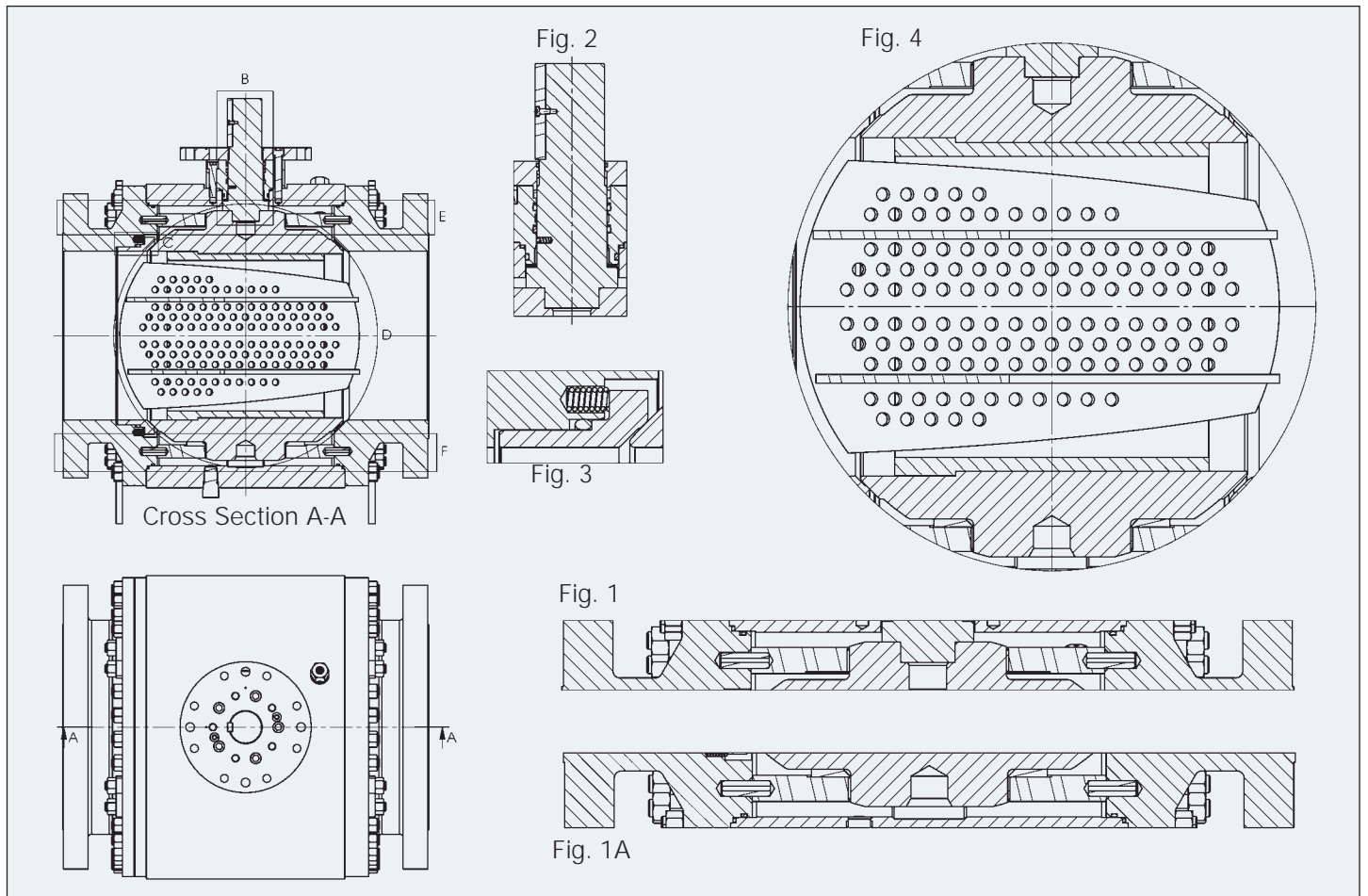

The operational properties mentioned in the previous paragraphs have some technical features that make Pibiviesse Cage-Ball valves unique. The major points are listed here below.

Fig 1) and Fig 1A) show how upper and lower support plates are designed for heavy duty service. The wide diameter bearings carry safely the pressure loads and thus minimize valve frictions and vibrations.

Fig 2) The stem is designed to be backlash free and not subject to bending with the

benefit of smoother operation and stem seals long-lasting life.

Fig.3) The seat is designed to be pressure assisted only when the ball is in fully closed position assuring smooth operability in modulating service. This means a significant reduction in ball surface wearing and long term bidirectional tight shut-off is achieved. Upstream sealing seat is not subject to flow erosion or impingement.

Fig.4) The structural integrity of the ball design is made of the most robust by

machining the trunnion to spherical geometry. This avoids the deformation while throttling under the fully rated pressure differentials.

The trunnions and consequently the bearings are generously designed with very low specific load allowing long lasting smooth backflash free operation.

The ball and the Cage-Ball cartridge are bidirectional and in case of excessive wear the ball can be simply rotated by 180°. By changing the seat the valve can be upgraded tight.

Rotary Control Valves

HYPER CAGEBALL™ Trim Concept

Operational properties and features of Hyper Cage-Ball control valves

In addition to the mechanical features of Cage-Ball, this line of control valves is designed for all applications where extremely high pressure drops at fully open valves are required.

The design combines the high efficiency of the multistage type trim with the Cv of a conventional ball valve that can be full or reduced bore. When full bore valve at full opening the Cv is equivalent to a length of pipe.

A remarkable feature is that both the labyrinth and flow bore can be configured to suit the service condition and to determine the control range to reach over 400:1.

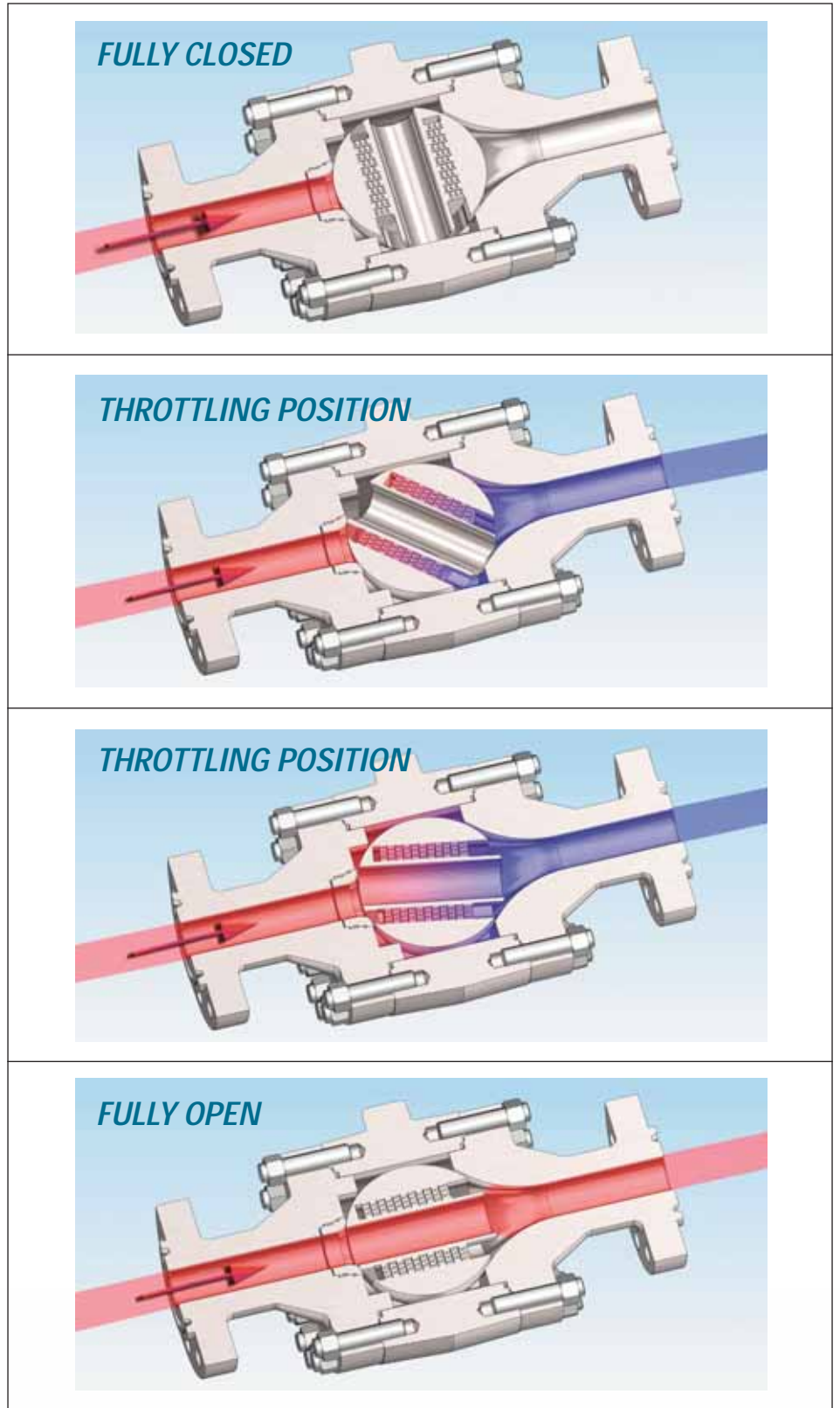
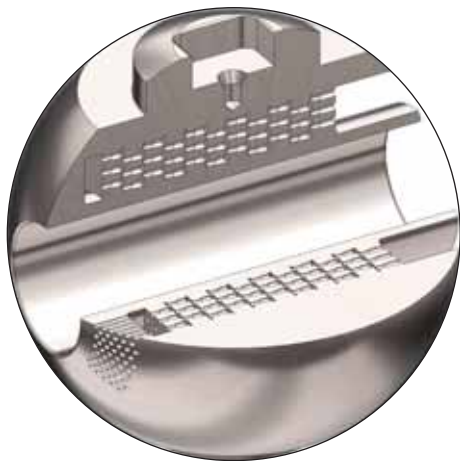

Rotary Control Valves

HYPER CAGEBALL™ Multistage Trim Concept

Operational properties and features of Multistage Hyper Cage-Ball control valves

This valve design combines the advantages of our Cage-Ball control valve with the advantages of our Hyper Cage-Ball. This design has been developed to allow smooth control of high/medium pressure drop with very small initial flow and very large flow at full opening while maintaining anti-cavitation and self-cleaning features. Also for this configuration the CV values can be customized to better suit the various service conditions.

One of the most common application of this design is for turbine's start-up, where generally two valves in split-range are used.

Due to nature of Hyper Cage design the capacity is always made suitable for the application.

Pibiviesse engineers shall design the best execution of the cartridge design based on the given process conditions.



FULLY CLOSED

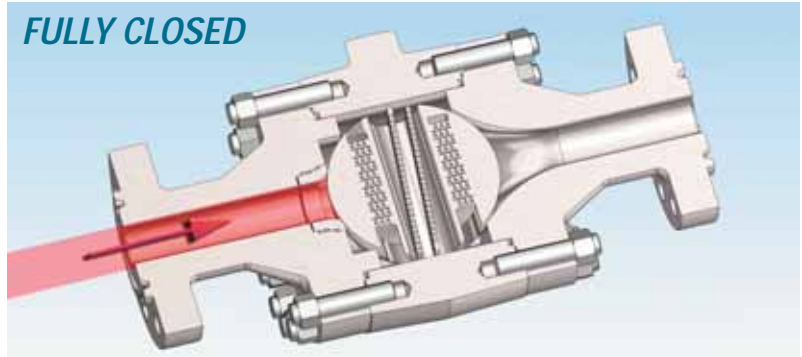

THROTTLING POSITION

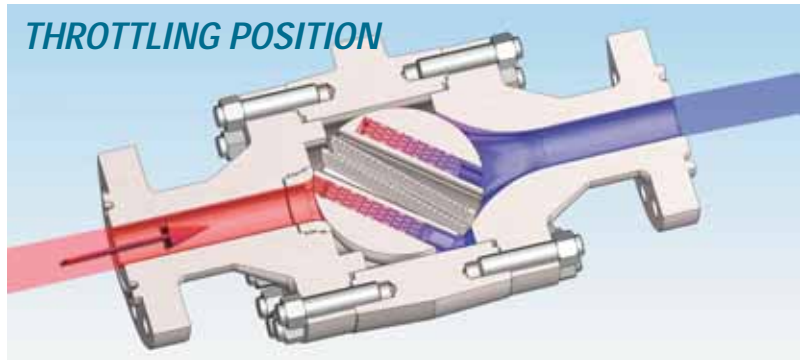

THROTTLING POSITION

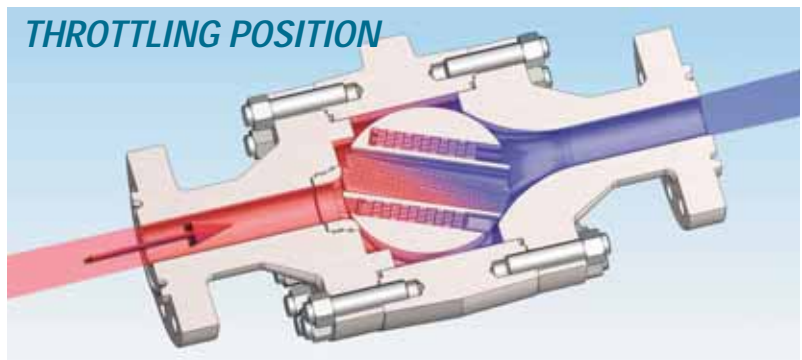

FULLY OPEN

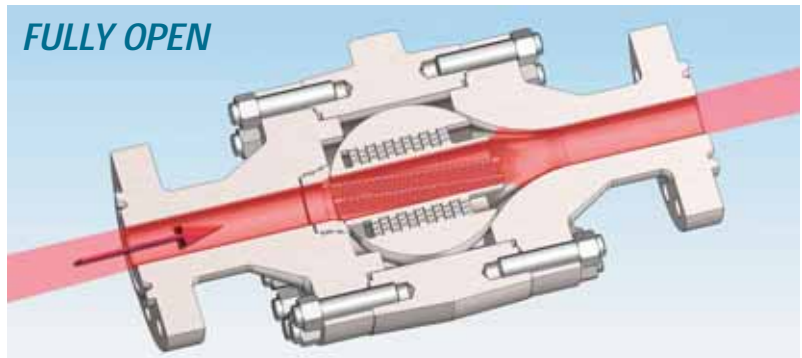

Rotary Control Valves

Guidelines

General

Selection of a control valve is a three phase process. Firstly the mechanical suitability of the valve according to pressures, temperatures, flowing fluid and as well local laws and rules. Secondly comes the physical valve sizing to be capable to pass convenient flow through the valve with acceptable margins of safety and noise generation. Thirdly the valve control behaviour must be suitable to meet the control loop (process) requirements.

Mechanical selection is based on good engineering practise and knowledge of the process fluid nature and behaviour (corrosion, erosion, mechanical strength etc). Valve sizing is based on given flow parameters. What is expected from the valve from capacity and noise wise. Wrong sizing can also affect valve wear and thus life time. In process performance, design control valves sizing can affect the process performance and efficiency.

Typical mistakes are too small valves leading to too high opening angle or too big valves leading to too small opening. Both can cause serious problems in control accuracy, noise and also valve mechanical life time. Valve behaviour in control loop is related to valve internal characteristics (design).

The characteristics are linear equal percentage or modified. The effect to flow is dependant of the valve opening.

Nomenclature

Capacity (C_v / k_v) = Valve flow coefficient which represents the capacity of a particular valve design. It is calculated and measured in laboratory and is listed in a table per every 10% of valve opening. Especially at small openings to intermediate Cage Ball is offering higher capacity compared to conventional solutions.



Rotary Control Valves

Guidelines

Valve noise

The biggest portion by far of noise is caused by cavitation in liquid flow. Generally it can be said that by controlling the velocity the noise gets taken care. The second noise source is large valves mass flow rates. Large size valves have normally smaller wall thickness which does not absorb the noise thus the noise level can be high. Flow path modification with Cage or Hyper-Cage shall be the most suitable solution to outcome from these problems.



Velocity

Flow velocity is an initiator of many valve performance measures. When the flow area within the valve internals is restricted constant flow needs increased velocity to pass the valve. Increased velocity is the cause of noise generation, erosion, cavitation, choked flow, corrosion, pipe vibration, etc. By splitting the pressure steps into several stages, by means of Cage Ball the velocity is reduced to level which does not cause flow disturbance.



Pressure Drop

Pressure drop is the pressure loss caused by the valve. Inlet pressure P_1 – outlet pressure P_2 = pressure drop. When selecting the valve for a control duty it is very important that the mechanical valve design can withstand the pressure drop ΔP also within the given process conditions.



Dynamic torque

Under differential pressure conditions the flow tends to open or close the valve. This is caused by an asymmetric pressure distribution on the surface of ball. This must be taken into account when selecting the actuator. Cage Ball balancing tails divide the dynamic forces evenly inside the trim internals and therefore reduce the dynamic forces.



Turndown

The ratio of plant maximum design flow rate to minimum designed flow rate. Cage and Hyper Cage Ball design have brought the turndown to a level of 1:250 or even higher. These turndown ratios have not been available with any conventional solutions till now.

Rotary Control Valves

Guidelines

Applications

Cage Ball and Hyper Cage Ball valves can be used in most low noise flow control applications where control accuracy is needed. It offers an axial flow through the valve port and thus eliminates several difficulties created by turbulent flow. The main benefits are still in High Pressure drop or Cavitating applications.

Oil & Gas

- Compressor Anti-Surge
- Compressor By-pass
- Compressor/pump recirculation
- Pressuring/depressuring
- Loading control
- Pump Start-up
- Cavitation control
- Noise & Vibration control
- Erosion control
- Reducing Stations
- Mixing & Metering



LNG

- Compressor Anti-surge
- Compressor By-pass
- Regasification
- Blowdown
- Metering Stations
- Flare depressuring



Power Industry

- Steam Control
- Noise Control
- Cooling water
- Large Flow Control
- Desuperheating



Rotary Control Valves

Guidelines

But in any steam, liquids, oil, gas, hydrates and erosive applications these valves are the most suitable. Also applications which need smooth switching or self cleaning benefit from the Cage Ball design. We list here a few applications by industry where Pibiviesse Cage Ball valves have been used:

Refining & Petrochemical

- Compressor Anti-surge
- Compressor By-pass
- Blowdown
- Feed stock feed
- Pressure Control
- Temperature Control
- Flow Control
- Level Control
- Scaling & Coking and Slurry Fluids Control



Desalination & Water

- Steam to Brine heater
- Desuperheating
- Δp Control



General

- Cavitation Control
- Noise & Vibration Control
- Erosion Control
- High Rangeability
- Clogging



Rotary Control Valves

CAGEBALL™ Cv Table

Control ball valve flow coefficient, nominal, full/reduced bore, bi-directional flow, single or double seated metal or soft seats.

Sizing coefficient Cv

| SIZE | | RELATIVE TRAVEL OPENING | | | | | | | | | | |
|-----------|-------|-------------------------|-------|-------|-------|-------|-------|-------|-------|-------|-------|--------|
| DN | INCH | >0* | 10% | 20% | 30% | 40% | 50% | 60% | 70% | 80% | 90% | 100% |
| 50 | 2 | 1,2 | 2 | 4 | 7 | 9 | 10 | 19 | 29 | 41 | 70 | 103 |
| 80x50 | 3x2 | 1,2 | 2 | 4 | 6 | 8 | 9 | 16 | 25 | 35 | 60 | 88 |
| 80 | 3 | 2 | 5 | 11 | 19 | 24 | 27 | 49 | 76 | 108 | 184 | 271 |
| 100x80 | 4x3 | 1,6 | 3 | 6 | 10 | 13 | 15 | 26 | 41 | 58 | 99 | 146 |
| 100 | 4 | 3 | 10 | 19 | 33 | 43 | 48 | 86 | 134 | 191 | 324 | 477 |
| 150x100 | 6x4 | 2 | 5 | 10 | 17 | 22 | 24 | 44 | 68 | 97 | 165 | 243 |
| 150 | 6 | 6 | 25 | 49 | 86 | 110 | 123 | 221 | 343 | 490 | 833 | 1225 |
| 200x150 | 8x6 | 3 | 8 | 16 | 28 | 36 | 41 | 73 | 113 | 162 | 275 | 405 |
| 200 | 8 | 10 | 42 | 84 | 147 | 189 | 210 | 377 | 587 | 838 | 1425 | 2095 |
| 250x200 | 10x8 | 5 | 13 | 26 | 45 | 57 | 64 | 115 | 179 | 255 | 434 | 638 |
| 250 | 10 | 12 | 71 | 141 | 247 | 317 | 353 | 635 | 987 | 1410 | 2397 | 3525 |
| 300x250 | 12x10 | 6 | 24 | 48 | 84 | 108 | 120 | 216 | 336 | 480 | 816 | 1200 |
| 300 | 12 | 16 | 101 | 202 | 354 | 455 | 505 | 909 | 1414 | 2020 | 3434 | 5200 |
| 350x300 | 14x12 | 9 | 40 | 80 | 140 | 180 | 200 | 360 | 560 | 800 | 1360 | 2000 |
| 350 | 14 | 22 | 124 | 247 | 432 | 556 | 618 | 1112 | 1729 | 2470 | 4199 | 6175 |
| 400x350 | 16x14 | 11 | 67 | 133 | 233 | 300 | 333 | 600 | 933 | 1333 | 2266 | 3332 |
| 400 | 16 | 30 | 165 | 331 | 579 | 744 | 827 | 1489 | 2316 | 3308 | 5624 | 8270 |
| 450x400 | 18x16 | 17 | 111 | 222 | 389 | 500 | 555 | 999 | 1554 | 2220 | 3775 | 5551 |
| 450 | 18 | 42 | 218 | 435 | 762 | 979 | 1088 | 1958 | 3046 | 4352 | 7398 | 10880 |
| 500x450 | 20x18 | 32 | 185 | 370 | 647 | 832 | 925 | 1665 | 2589 | 3699 | 6289 | 9248 |
| 500 | 20 | 55 | 275 | 551 | 964 | 1239 | 1377 | 2479 | 3856 | 5508 | 9364 | 13770 |
| 600x500 | 24x20 | 48 | 308 | 616 | 1078 | 1387 | 1541 | 2773 | 4314 | 6163 | 10477 | 15410 |
| 600 | 24 | 65 | 425 | 850 | 1488 | 1913 | 2125 | 3825 | 5950 | 8500 | 14450 | 21250 |
| 700x600 | 28x24 | 56 | 339 | 678 | 1186 | 1525 | 1694 | 3049 | 4743 | 6776 | 11519 | 16940 |
| 700 | 28 | 75 | 474 | 949 | 1660 | 2134 | 2372 | 4269 | 6640 | 9486 | 16126 | 23715 |
| 750x700 | 30x28 | 63 | 439 | 879 | 1538 | 1977 | 2197 | 3955 | 6152 | 8788 | 14940 | 21970 |
| 750 | 30 | 81 | 615 | 1231 | 2154 | 2769 | 3077 | 5539 | 8616 | 12308 | 20924 | 30770 |
| 800x750 | 32x30 | 82 | 502 | 1003 | 1755 | 2257 | 2508 | 4514 | 7021 | 10030 | 17051 | 25075 |
| 800 | 32 | 90 | 702 | 1404 | 2457 | 3159 | 3511 | 6319 | 9829 | 14042 | 23871 | 35105 |
| 900x800 | 36x32 | 85 | 643 | 1286 | 2250 | 2893 | 3214 | 5785 | 8999 | 12856 | 21855 | 32140 |
| 900 | 36 | 110 | 900 | 1800 | 3150 | 4050 | 4500 | 8100 | 12600 | 18000 | 30600 | 45000 |
| 1000x900 | 40x36 | 97 | 809 | 1617 | 2830 | 3639 | 4043 | 7277 | 11320 | 16172 | 27492 | 40430 |
| 1000 | 40 | 220 | 1132 | 2264 | 3962 | 5094 | 5660 | 10188 | 15848 | 22640 | 38488 | 56600 |
| 1200x1000 | 48x40 | 210 | 1970 | 3735 | 6535 | 8400 | 9333 | 16800 | 26130 | 37235 | 62925 | 92500 |
| 1200 | 48 | 480 | 2590 | 5182 | 9068 | 11660 | 12955 | 23319 | 36260 | 51800 | 88060 | 129500 |
| Cv/d2 | | | 0,87 | 1,75 | 3,05 | 3,93 | 4,36 | 7,86 | 12,20 | 17,50 | 29,70 | 43,60 |
| Fl | | | >0,97 | >0,97 | >0,95 | 0,95 | 0,93 | 0,93 | 0,92 | 0,91 | 0,89 | 0,85 |
| Xt | | | 0,86 | 0,86 | 0,85 | 0,85 | 0,80 | 0,75 | 0,68 | 0,62 | 0,58 | 0,49 |
| α | | | 0,018 | 0,02 | 0,03 | 0,05 | 0,075 | 0,09 | 0,15 | 0,22 | 0,43 | 0,55 |

Notes:

(*) Minimum controllable flow coefficient

1) Indicated Cv for valve rating up to 600# - above use the reducing factor: 900 LBS = 0,95, 1500 LBS = 0,9, 2500 LBS = 0,8

2) Pipe size will affect given Cv – Use Fp correction factor

3) For special trim please refer to the factory

PIBIVIESSE S.r.l.

20014 NERVIANO (Milano) - ITALY - Via Bergamina, 24
Phone +39 0331 408711 - Fax +39 0331 408802
e-mail: info@pibiviesse.it - www.pibiviesse.it